

917.2

DOUBLE FORK POSITIONER FOR 1-2 PALLET

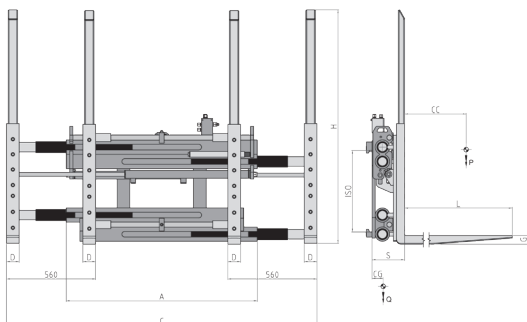

Model 917.2 allows to move one or two pallets side by side, small dimension of the frame ease operations in small spaces. The four bolt-on forks make the substitution easy and are supplied as standard with reinforced heel and load backrest.

REFERENCE	ATTACHMENT CAPACITY	LOAD CENTRE	ISO 2328 FEM	CARRIAGE WIDTH	OPENING RANGE		FORKS		THICKNESS	CENTER OF GRAVITY	WEIGHT
	P - Kg	CC - mm			C MIN - mm	C MAX - mm	DxGxL mm	H mm	S - mm		
15REA2A0004	2200	600	II	1200	560	1940	80x40x1150	1460	154	190	450
15RFB2A0005	2500	600	II	1200	560	1940	80x50x1150	1460	164	205	550
15RFB3A0005	2600	600	III	1200	560	1940	80x50x1150	1460	164	200	520
15RHF3A0005	3200	600	III	1200	560	1940	80x60x1150	1460	174	205	575
15RJV3A0003	4000	600	III	1400	560	1940	80x60x1150	1460	174	190	610

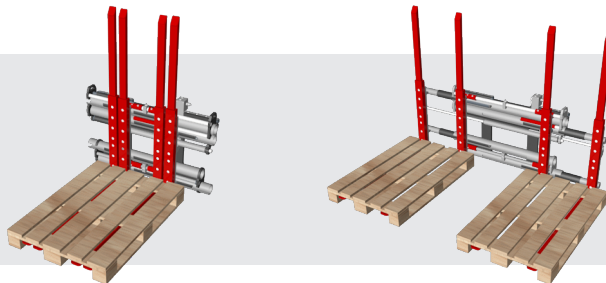

Hydraulic functions required: 1.
Maximum working pressure: 200 bar.

The references indicated on table are relative to standard attachments.
For the position of hydraulic connection see detail below.

