

# 917.T4

## DOUBLE FORK POSITIONER WITH SEMI-INTEGRAL SIDESHIFT FOR 1-2-4 PALLET

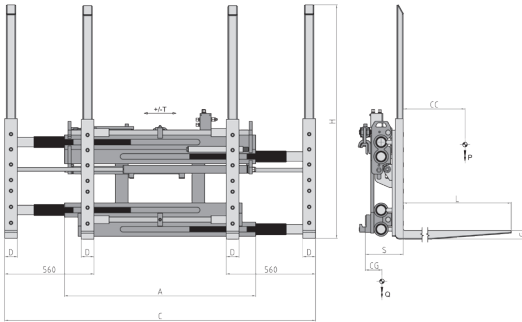

Model 917.T4 allows to move one or two pallets side by side, or four pallets in double depth, small dimension of the frame ease operations in small spaces. The four bolt-on forks make the substitution easy and are supplied as standard with reinforced heel and load backrest. Semi-integral side shift facilitates even more the handle of the pallet.

REFERENCE	ATTACHMENT CAPACITY	LOAD CENTRE	ISO 2328 FEM	CARRIAGE WIDTH	OPENING RANGE		FORKS		STROKE	THICKNESS	CENTER OF GRAVITY	WEIGHT
	P - Kg	CC - mm			C MIN - mm	C MAX - mm	DxGxL mm	H mm				
<b>15RFC3A1001</b>	2500	1200	III	1400	560	1940	80x60x2400	1460	100	225	480	1050
<b>15RJ64A1001</b>	3600	1200	IV	1400	560	1940	80x70x2400	1460	150	235	435	1320
<b>15RKY4A1001</b>	4600	1200	IV	1400	560	1940	80x70x2400	1460	150	235	445	1380

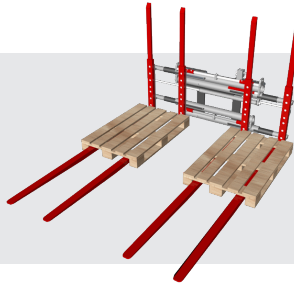
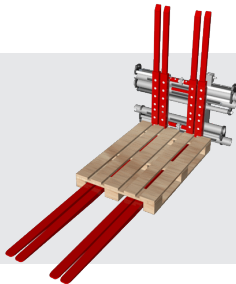

Hydraulic functions required: 2.  
Maximum working pressure: 200 bar.

The references indicated on table are relative to standard attachments.  
For the position of hydraulic connection see detail below.

